

Miele

Operating Instructions

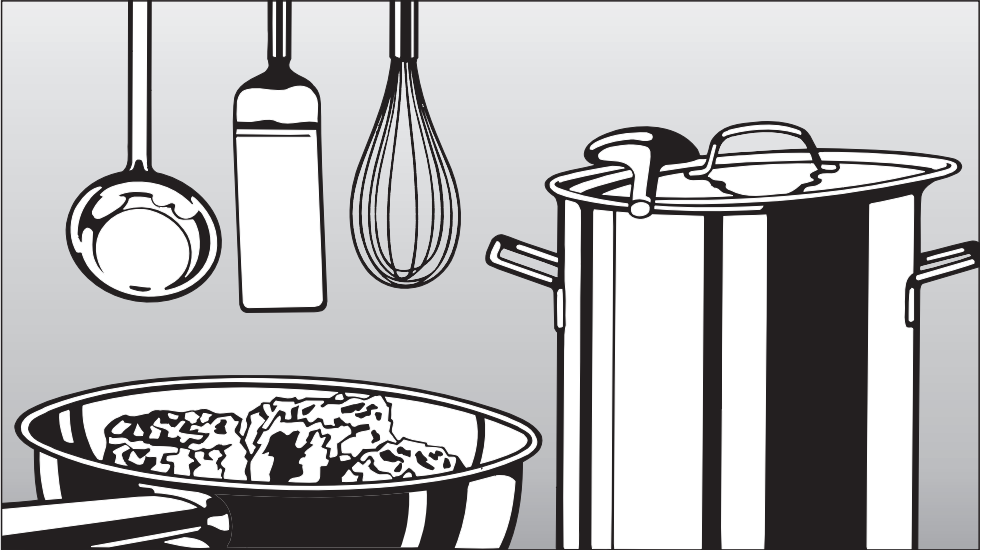

Fryer KM 403

To prevent accidents and reduce machine damage, read these Instructions **before** installation or use.



M.-Nr. 05 825 170

IMPORTANT SAFETY INSTRUCTIONS	4
Guide to the fryer	8
Before using for the first time	9
Cleaning before the first use	9
Using the fryer	10
Turning on and off	10
Before frying	10
Frying	11
Frying tips	13
After frying	14
Safety cut-out feature	15
Cleaning and care	16
Frying basket	16
Reservoir	17
Stainless steel frame	18
Ceramic control panel	18
Lid	18
Frequently asked questions	19
After sales service	20

IMPORTANT SAFETY INSTRUCTIONS

Installation

When using your appliance, follow basic safety precautions including the following:

- Read all instructions before using for the first time.
- Be certain your appliance is properly installed and grounded by a qualified technician.
- To guarantee the electrical safety of this appliance; continuity must exist between the appliance and an effective grounding system. It is imperative that this basic safety requirement be met. If there is any doubt, have the electrical system of the house checked by a qualified electrician. The manufacturer cannot be held responsible for damages caused by the lack or inadequacy of, an effective grounding system.
- Do not connect the appliance to the main electrical supply using an extension cord. Extension cords do not meet the safety requirements of this appliance.
- Before servicing, disconnect the power supply by either removing the fuse, shutting off the power main, or manually "tripping" the circuit breaker.

Correct usage

- Do not operate the appliance until it is properly installed in the countertop.
- This appliance is intended for residential use only.
- Use the appliance only for its intended purpose. The manufacturer cannot be held responsible for damages caused by improper use of the fryer.
- Never use the appliance to warm or heat the room.
- Only use oils or fats that are recommended for deep fryer use. Never mix different types of oil and fat.
- Turn on the fryer only after the lid is removed and it is filled with oil or water.
- Do not switch on the appliance when the heating element is raised for cleaning.
- Always lower the heating element into the operating position when the appliance is not in use.
- This appliance must not be set up or operated outdoors.
- This equipment has not been designed for maritime use or for use in mobile installations such as aircraft or recreational vehicles. However, under certain circumstances it may be possible for an installation in these applications. Please contact the nearest Miele Dealer or the Technical Service Department with specific requirements.

IMPORTANT SAFETY INSTRUCTIONS

Protection from burns

Do not leave the fryer unattended while in use. Overheated oil can ignite. Do not allow an open flame in the vicinity of the fryer.

Do not let cooking grease or other flammable materials accumulate on the appliance. Make certain there are no open flames present when adding oil to the fryer.

Do not use water on grease fires. Smother or use a dry chemical or foam extinguisher on any fire or flame.

To avoid personal injury, use extreme caution when lifting the basket from the reservoir or filtering the hot oil.

Caution: Never put water or ice into hot oil; this can cause a steam explosion leading to injury.

Oil should be strained through a paper filter between uses. Oil containing impurities may ignite. Replace oil regularly.

Do not allow children to operate or play with or near the fryer.

Do not store toys or items of interest to children in cabinets above or behind the appliance. Children climbing onto the fryer to reach these items may be seriously injured.

Use only dry, heat resistant potholders. Moist or damp potholders used on hot surfaces can result in steam burns. Do not let the potholder touch the hot heating elements or come in contact with the oil or water. Do not use towels or other bulky items near the appliance.

Be aware of loose fitting or hanging garments when operating the cooktop, they may present a fire hazard.

Do not store aerosols, combustibles or any other easily flammable materials underneath or adjacent to the appliance.

IMPORTANT SAFETY INSTRUCTIONS

Protection from damage

■ Do not drop anything on the ceramic surface. Even a light object could cause damage.

■ Any breaks or cracks in the ceramic surface of the appliance are defects and must be treated as such. Do not use the appliance until it has been repaired.

■ In the event of any damage to the appliance, it must be turned off immediately and disconnected from the electricity supply by either removing the fuse, unplugging the unit or manually "tripping" the circuit breaker. Contact Technical Service .

Do not use the appliance until it has been repaired.

Ensure power is not supplied to the appliance while repair work is performed.

■ Repairs should only be performed by qualified technicians to ensure safety. Repairs and other work by unqualified persons could be dangerous. Under no circumstances open the outer casing of the appliance.

■ While the appliance is under warranty repairs should only be performed by an authorized service technician. Otherwise the warranty is void.

■ Do not use a steam cleaner to clean the appliance. Steam could penetrate electrical components and cause a short circuit.

IMPORTANT SAFETY INSTRUCTIONS

Further safety notes

■ Make certain that the power cords of small appliances do not come in contact with the fryer.

■ Always make sure food is cooked thoroughly before eating.

■ Cook pork thoroughly to ensure that it is safe to eat.

■ Do not store or transport hot oil in plastic containers. Plastic melts!

■ Frying oil is no longer usable and must be replaced when it becomes dark and thick, smells unpleasant or froths and smokes at a temperature of 340 °F (170 °C) or less.

■ Do not pour oil or fat down the sink. Oil and fat can block the drain pipes or cause septic problems. Consult your local sewage or sanitation authority for the proper disposal of oil or fat.

■ Allow hot oil to cool before draining the fryer.

■ Before disposing of an appliance, remove the power cord and any doors to prevent hazards.

SAVE THESE INSTRUCTIONS AND REVIEW THEM PERIODICALLY

Guide to the fryer

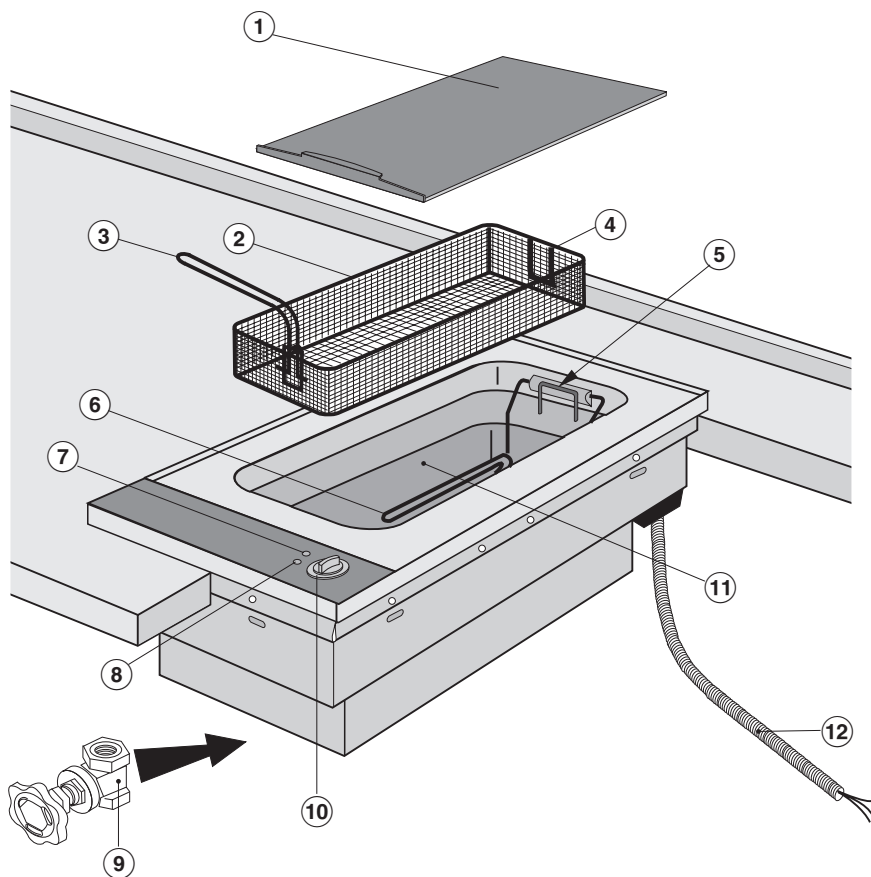

- ① Lid
- ② Frying basket
- ③ Handle (removable)
- ④ Basket clip
- ⑤ Basket support
- ⑥ Heating element (can be raised)
- ⑦ Temperature indicator light
- ⑧ Operating indicator light
- ⑨ Drain valve
- ⑩ Control knob
- ⑪ Reservoir for oil
- ⑫ Power cord

Before using for the first time

Cleaning before the first use

Clean the fryer to remove any foreign materials or dust.

- Make sure the drain valve is closed.
 - Fill the reservoir with approximately 1 gallon (4 l) of water and add a small amount of dish soap. Make sure the water level is no higher than the maximum level marked on the rear of the reservoir.
 - Turn the control knob clockwise to 275 °F (130 °C) and bring the water to a boil.
 - Once the water starts to boil, turn off the fryer by turning the control knob counterclockwise to "0". Allow water to cool to a safe temperature before draining. Empty the water into a heat resistant container by opening the drain valve (see "After frying").
- Rinse the reservoir thoroughly with clean hot water.
 - Close the drain valve, raise the heating element, and dry the reservoir with a clean cloth.

Using the fryer

Turning on and off

Turn the control knob clockwise, ①, to turn the fryer on and counterclockwise, ②, to "0" to turn the fryer off.

You cannot turn the control knob to "0" by turning the knob clockwise past 400 °F (200 °C).

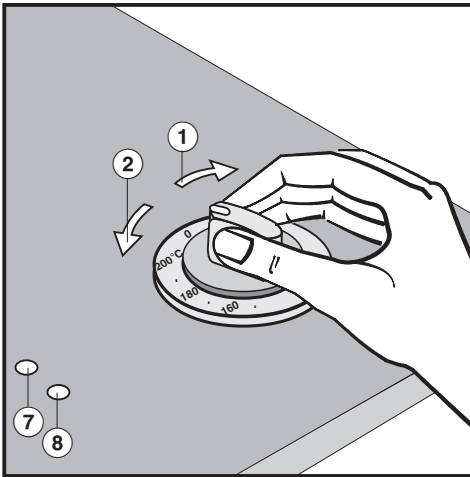

The temperature indicator light, ⑦, and the operating indicator light, ⑧, will illuminate whenever the control knob is in any position besides "0".

The temperature indicator illuminates when the oil is heating to the selected temperature and goes out once the temperature is reached.

Never operate the fryer with the lid on.
Never turn on the fryer when it is empty or when the heating element is raised.

Before frying

Before frying, make sure the reservoir has been filled with enough frying oil (min: 3 qt.(3 l) - max: 4 qt. (4 l)).

Only use oil or fat specifically for deep fryer use. Never mix different types of oils and fats.

Correct procedure:

- Fill the oil reservoir. Solid fat should be cut into small pieces first.
- When reheating fat that has solidified in the reservoir, make a hole in the fat with a blunt utensil as far down as the heating element. This will allow any trapped water to evaporate.
- Turn the control knob to 212 °F (100 °C) and wait until the fat has completely melted.

Check the level in the reservoir after the fat has melted. It must be between the minimum and maximum levels as marked on the rear wall of the reservoir.

Frying

- Set the desired frying temperature (see table on next page). Once the temperature indicator light goes out the oil has reached temperature.
- Place the frying basket containing the food into the hot oil. If the oil froths a lot, briefly remove the basket from the reservoir and slowly reimmerse.
- Remove the basket from the hot oil when the food has finished cooking. Give the basket a slight shake to remove excess oil. Hang the basket from the basket support.

Do not touch hot oil. Protect your hands by wearing oven mitts and remove hot food using the proper utensils.

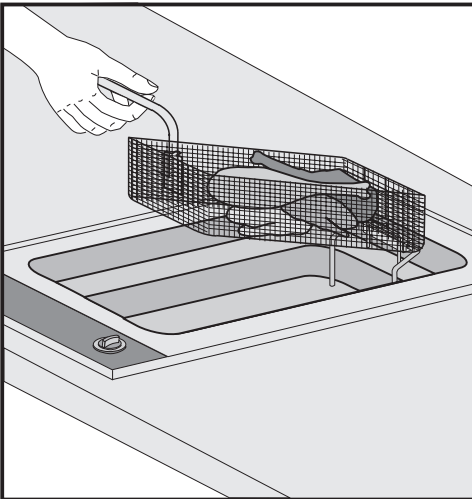

- When no longer dripping, place the food on paper towels to soak up excess oil.

Using the fryer

Fresh food	Quantity	Temperature °F (°C)	Frying time in minutes
Steak fries	1 lb. (500 g)	355 (180)	4 - 6
French fries	1 lb. (500 g)	355 (180)	3 - 5
Chicken fingers	4 pieces 2 oz. (60 g) each	355 (180)	8 - 10
Unbreaded, turkey cutlets	2 pieces 8 oz. (250 g) each	355 (180)	3 - 5
Veal cutlets	7 oz (200 g)	355 (180)	5 - 7
Cheese sticks	10 oz. (290 g)	355 (180)	2 - 3
Mushrooms	1 lb. (500 g)	355 (180)	2 - 3
Doughnuts	4 pieces	335 (180)	6 - 8
Jelly doughnuts	5 pieces	335 (180)	6 - 8
Apple fritters	4 pieces	355 (180)	6 - 8
Banana fritters	2 pieces	355 (180)	3 - 4
Raw vegetables, in batter	1 lb. (500 g)	355 (180)	8 - 10

Frozen food	Quantity	Temperature °F (°C)	Frying time in minutes
Steak fries	1 lb. (500 g)	355 (180)	4 - 6
	2 lbs. (1 kg)	355 (180)	8 - 10
French fries	1 lb. (500 g)	355 (180)	3 - 4
Fish sticks	10 oz (290 g)	355 (180)	4 - 6
Unbreaded, fish fillets	10 oz. (290 g)	335 (180)	3 - 5
Calamari	8 oz. (250 g)	355 (180)	2 - 3

Please note: Times given are only a guide. Actual cooking times will vary depending on the size and quantity of the food being cooked.

Frying tips

- The oil must be hot enough to seal and cook the food quickly. If the temperature is too low, the food will absorb oil. Wait until the temperature indicator light goes out (which means the set temperature has been reached), before placing food into the fryer.
- Do not fry too much food at once. This will lower the temperature of the oil long enough to cause the food to absorb oil.
- Food should be as dry as possible since moisture can cause frothing. Dab wet or moist food with paper towels until dry and remove any traces of ice from frozen food.
- Lower the frying basket into the reservoir slowly to prevent oil from splashing or frothing.

Do not add salt, powders or sauces to food while the basket is over hot oil. This can cause the oil to "spit" or froth which could cause burns.

Using the fryer

After frying

Turn off the fryer and let the oil cool. Filter the oil to remove impurities that can ignite. This will also extend the life of the oil.

Filtering the oil:

- Make sure that the under side of the fryer is accessible so the oil can be drained.
- Let the oil cool to a safe temperature before draining to prevent burns. If the oil has solidified, melt it by briefly setting the fryer to 212 °F (100 °C) and then turning it off.
- Place a heat resistant container of a suitable size, such as a metal pot, under the drain valve. Only use containers that are able to withstand heat to collect the oil.
- Slowly open the drain valve by turning it counterclockwise ①.

- Close the valve after all the oil has drained by turning it clockwise, ②, (do not over-tighten the valve). Make sure that the valve is closed.
- Filter the oil by passing it through a strainer lined with a paper filter.
- Wipe up any residues remaining in the reservoir. The heating element can be raised to make this easier.
- When finished cleaning, lower the heating element and slowly pour the filtered oil back into the reservoir. Check the level and add fresh oil as necessary. Place the lid on the fryer to protect the oil.

Change the oil when it:

- is very dark and does not pour easily.
- smells unpleasant or froths.
- begins to smoke at a 340 °F (170 °C) or less.

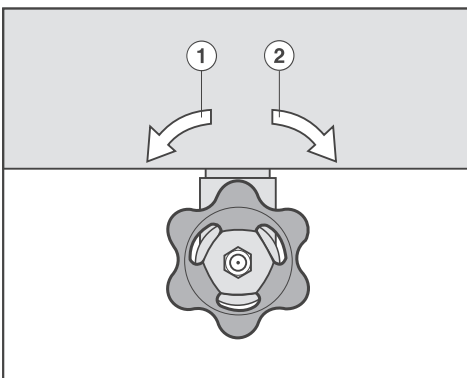

Safety cut-out feature

The fryer is equipped with a safety cut-out feature that automatically shuts off the fryer when:

- the reservoir is not filled to the proper level.
- the fryer is turned on when empty.
- the fryer is turned on while the heating element is raised.

The safety cut-out feature has activated when the temperature and operating indicator light do not illuminate.

How to reset the safety cut-out feature:

- Turn the control knob to "0" and wait until the heating element has cooled.
- Identify and correct the cause of the automatic safety cut-out.
- Press the reset button located underneath the left rear of the fryer and then turn on the appliance. If the indicator lights, you may resume cooking.

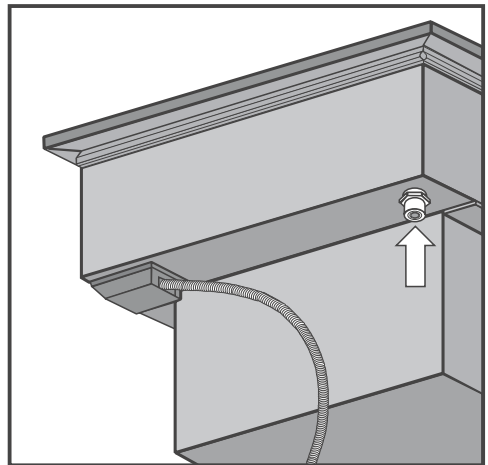

If the fryer is still inoperative, check for a "tripped" circuit breaker or a blown fuse.

Cleaning and care

Never use a steam cleaner to clean this cooktop. Pressurized steam could cause permanent damage to the surface and to components for which the manufacturer cannot accept responsibility.

Do not use any sharp or pointed objects which could damage the seal between the frame and the countertop.

Never use scouring agents, pads, abrasive cleaning agents, or strong cleaners e.g. oven sprays, stain or rust removers, as these will damage the surface of the appliance.

Dry your fryer thoroughly after cleaning it to prevent water stains.

Frying basket

Do not clean the frying basket in a dishwasher!

Clean the frying basket after each use by hand with hot water and liquid dish soap. Dry thoroughly.

It is best to soak burnt on food before cleaning.

The handle can be removed for cleaning.

Reservoir

- Make sure the fryer is off and the oil is cool before draining the reservoir for cleaning (see "After Frying").

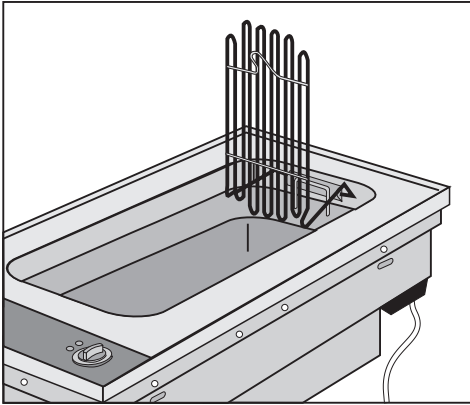

Do not use stainless steel cleaners or conditioners in the reservoir.

- Raise the heating element.
- Remove large particles and sediment with paper towels.
- Fill the reservoir with a solution of warm water and dish soap. Wash out the reservoir using a sponge or a soft non-scratching brush.
- Drain the water and soap from the reservoir and rinse thoroughly with warm water. Dry with a clean dish towel.

Cleaning and care

Stainless steel frame

Clean the stainless steel frame with hot water and liquid dish soap applied with a soft sponge. Wipe dry using a soft cloth.

The stainless steel frame can be cleaned using a non-abrasive stainless steel cleaner.

To help prevent resoiling, a conditioner for stainless steel can also be used. Apply sparingly with even pressure.

Ceramic control panel

Clean the ceramic surface and control knob with a damp cloth only, and then wipe dry.

Lid

Gently clean the lid with a solution of hot water and liquid dish soap applied with a sponge. Wipe dry with a dish towel.

Frequently asked questions

 Repairs should only be carried out by a qualified and trained person in accordance with local and national safety regulations. Unauthorized repairs could cause an injury or machine damage.

What if the indicator lights do not illuminate and the fryer does not heat?

Possible fault	Fix
The fryer is not on.	Turn the control knob clockwise to a selected temperature.
The safety cut-out feature has activated.	Turn the control knob counterclockwise to "0" and check if the safety cut-out button has "popped-out". If the button has "popped-out", refer to "Safety cut-out feature".
The fryer tripped the circuit breaker.	Check the service panel for a tripped circuit breaker and reset. If power cannot be restored, contact Technical Service.

What if the oil has an unpleasant odor or smokes when heated?

Possible fault	Fix
The oil is old or rancid.	Replace the oil with new oil.
The oil is not recommended for frying.	Use oil or fat specifically labelled as being suitable for deep frying.

What if the food is not crisp and brown or has an oily taste?

Possible fault	Fix
The oil was not hot enough.	Increase the frying temperature.
The basket was overloaded.	Do not overload the basket. Leave enough space in the basket so food can separate when immersed in the oil.

After sales service

In the event of a fault which you cannot correct, contact the Miele Technical Service Department

USA 1-800-999-1360
techserv@mieleusa.com

CDN/F 1-800-565-6435
service@miele.ca

When contacting the Technical Service Department, please quote the model and serial number of your appliance. These are shown on the data plate.

Adhere data plate sticker here

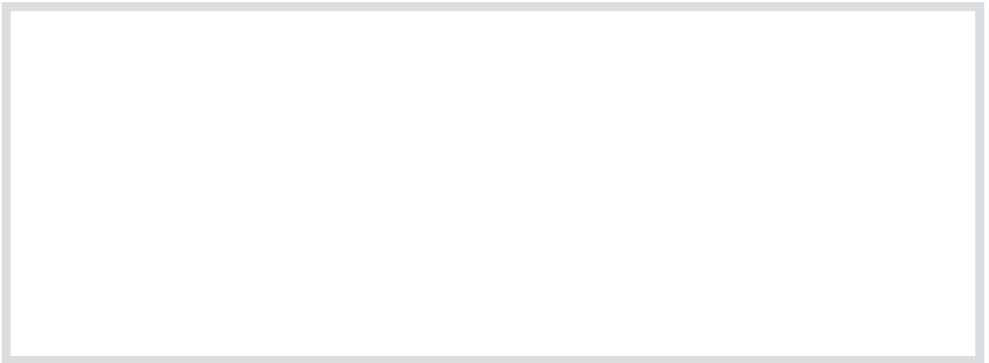

When contacting the Technical Service,
please quote the model and serial number
of your appliance.



Miele, Inc. (USA)

National Headquarters

9 Independence Way
Princeton, NJ 08540
Phone: 800-843-7231
609-419-9898
Fax: 609-419-4298
www.mieleusa.com

Technical Service & Support

Nationwide

Phone: 800-999-1360
Fax: 888-586-8056

Miele Limited (CDN)

National Headquarters

55G East Beaver Creek Road
Richmond Hill, ON L4B 1E5
Phone: 800-643-5381
905-707-1171
Fax: 905-707-0177
www.miele.ca
info@miele.ca (general enquiries)
professional@miele.ca (commercial enquiries)

Mielecare National Service

Phone: 800-565-6435
905-850-7456
Fax: 905-850-6651
service@miele.ca (Tech. Service)